

DRAW WIRE

Draw Wire Position Transducer for Hydraulic Cylinder Typ: SX300-15-SSI-F1

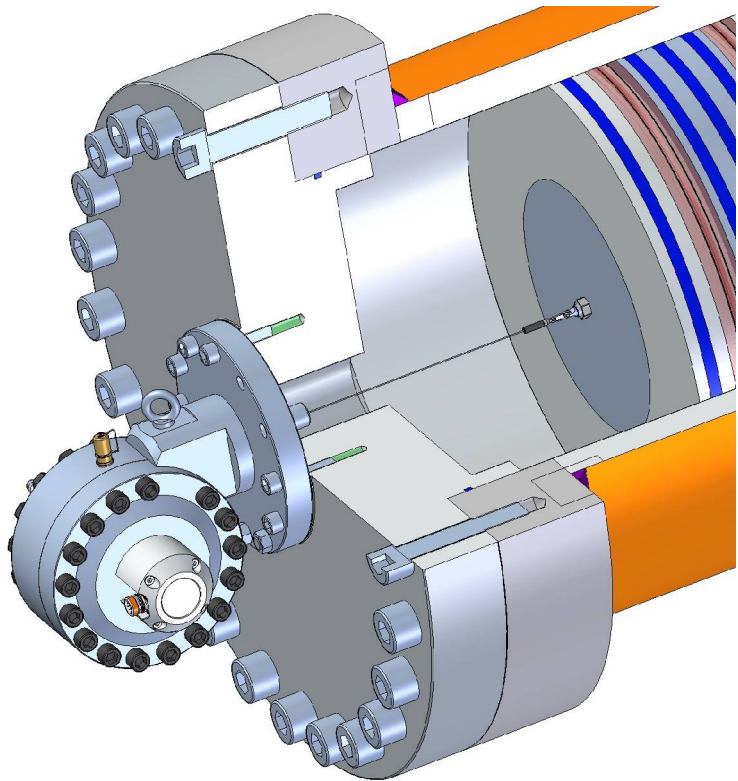

- **Ranges up to 15 m**
- **Output types:**
 - **Digital: RS422/TTL/push-pull**
 - **Digital-Absolute: SSI-Gray, Parallel-Gray**
 - **Bus system: Profibus DP, CANopen, DeviceNet, Interbus K3**
- **Linearity**
 - **Digital/Digital-Absolute/Bus $\pm 0,05\%$ of FS**
- **Protection class up to IP67**
- **High dynamics, high EMC-grade**
- **Customised versions available**

PRODUCT DESCRIPTION

WayCon Draw Wire Position Transducer SX300-Series are designed for use in conjunction with hydraulic cylinders and measuring the cylinder position. Especially designed for long stroke cylinders with pressurized housings to be flanged directly to the cylinder head. With giving feed back signal to a machine control unit, it is possible to control the position of the cylinder, program specific movements or managing synchronous movement of several cylinders.

Due to its small overall size, its short assembly time and its possible customisation, this sensor technology is a cost-effective and flexible solution for a wide range of industrial applications.

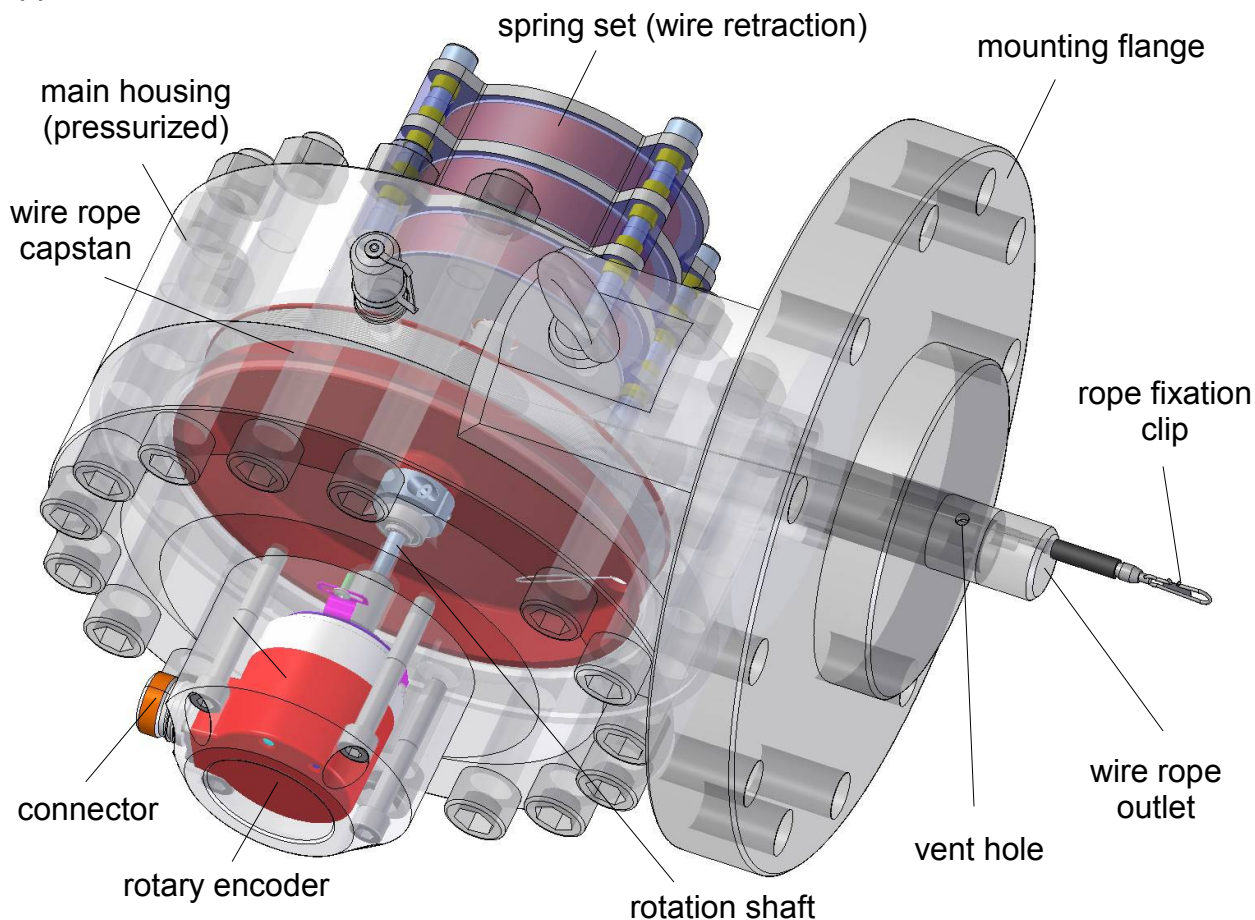

A constant spring force coils the measuring rope accurately single-layered on an wire rope capstan, so that its linear motion is converted into rotation. The sensor element (rotary encoder) provides the output signal required. The dynamics of the draw wire transducer allows a high motion speed and max. acceleration of the cylinder piston. Its high quality makes applications in harsh industrial environments possible.

Applications:

- hydraulic gates for dam control
- sluice gate control
- synchronous run of more than one cylinder
- cylinder acceleration and speed control
- stroke control of fairground ride applications

TECHNICAL DATA

Transducer - technical data

Measurement range	15.000 mm
Temperature range	-20...+70°C
Resolution	13 bit/568,9 mm
Resolution in pulses	14,4 pulses/mm
Linearity	±0,05%
Pressure port	Minimess 1620
Operational pressure	30 MPa (300 bar)
Max. pressure	37,5 MPa (375 bar)
Travel speed (piston)	1 m/s
Max. acceleration (piston)	1 m/s ²
Max. wire sag (calculated)	<30 mm
Weight	61 kg
Rope tension with set of 3 springs (optional 4 springs):	
Start of range:	10...11,5 N (13...16,5 N)
End of range:	29...31,5 N (37...43 N)
Encoder, blind hollow shaft 15mm	SSI, Art. Nr. 8.5883.6624.G322
Plug orientation	across from flange, 90° adjustable

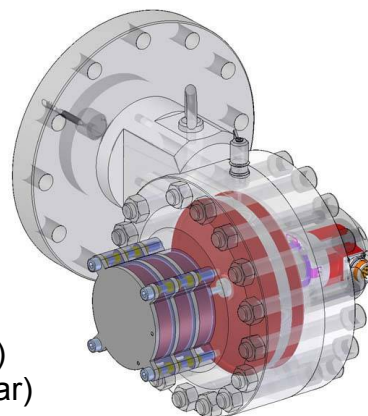

Encoder - technical data

Interface characteristics SSI

Singleturn resolution/code:	13 bit/Gray
SSI clock rate:	50 kHz ... 2 MHz

Mechanical characteristics:

Protection acc. to EN 60 529	IP 67
Working temperature	-40...+90°C
Shock resistance DIN-IEC 68-2-27	>2500 m/s ² , 6 ms
Vibration resistance DIN-IEC 68-2-6	>100 m/s ² , 55 ... 2000 Hz

General electrical characteristics:

Supply voltage:	10 ... 30 V DC
Current consumption 24 V DC:	max. 20 mA (w/o output load)
Reverse polarity protection	yes (at power supply U _b)
Conforms to CE requirements acc. to	EN 61000-6-1, EN 61000-6-4, EN 61000-6-3

General interface characteristics:

Output driver:	RS 485 transceiver type
Permissible load/channel:	max. +20 mA
Signal level high:	typ 3.8 V
Signal level low:	typ 1.3 V (I load = 20 mA)
Short circuit proof outputs:	yes (to 0V or output, supply correctly applied)

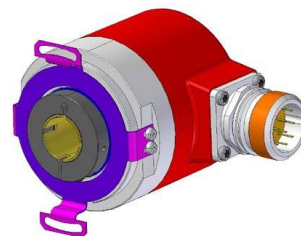

Mounting procedure instruction

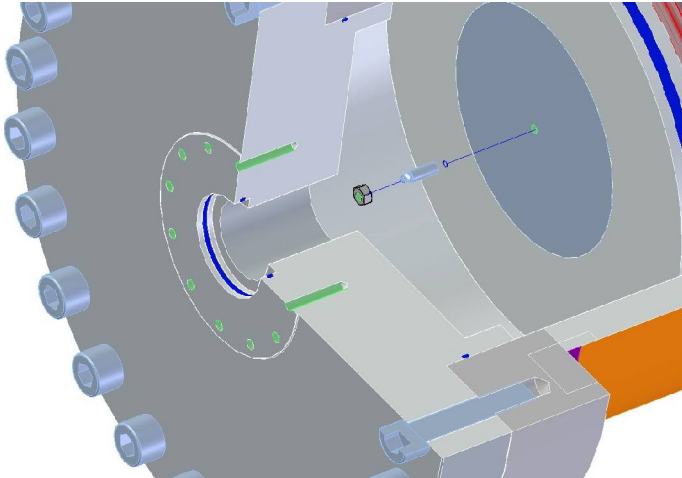

The wire fixation unit has to be screwed into the piston of the cylinder and locked with counternut.

Note: use screw locking device. If it is not possible to work through the cylinder head bore, you have to take off the cylinder head (please refer to the cylinder manual).

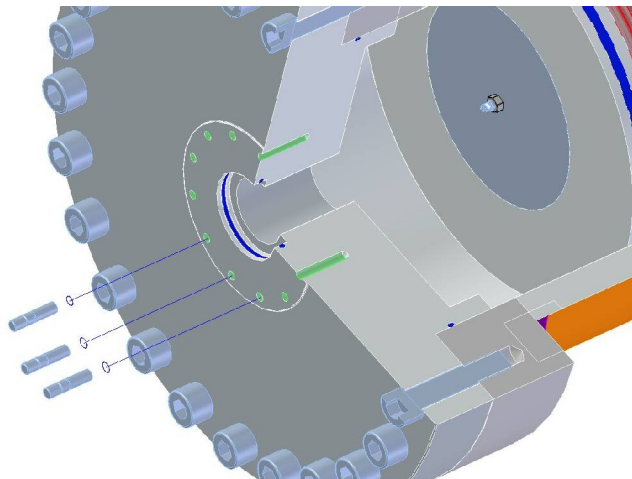

Install 3 stud bolts at the cylinder head.

At the bottom side of the transducer flange, 3 stud bolts are necessary, where no standard bolts can be feed through the bores. Please refer to your installation drawing about the position of the transducer.

Note: stud bolts greased with MoS2 if not defined otherwise in the cylinder manual. Please refer to the cylinder manual.

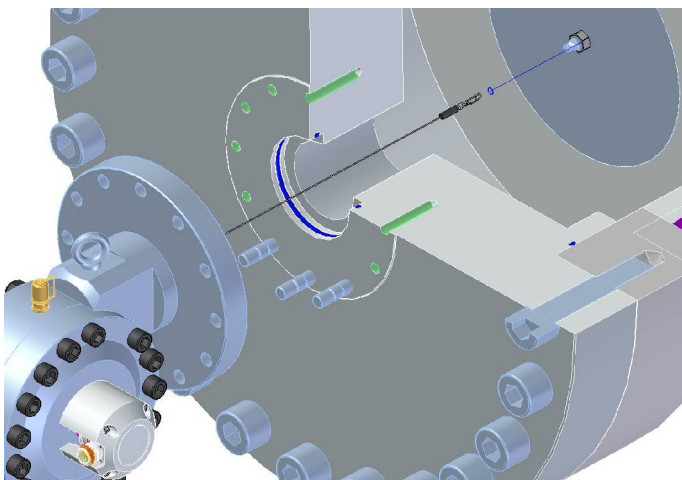

Move transducer nearby the cylinder head bore (use lifting device e.g. crane). Remove the protection cap above the wire outlet. Open the clip (carabiner) and feed the wire through the bore. Hook in the clip into the wire fixation and close the interlock snap.

Note: Don't let the rope snap back. If the rope is retracted freely, this may lead to injuries and the transducer may be damaged. Caution when unhooking and retracting the rope into the sensor. Avoid guiding the rope over edges or corners.

INSTALLATION (short form)

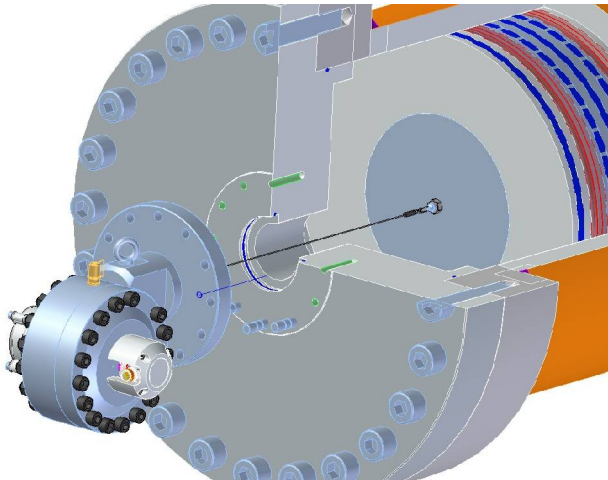

Move the transducer to the cylinder head and feed the stud bolts through the flange bores.

Note: Avoid guiding the rope over edges or corners. Be aware of the o-ring and refer to the cylinder manual. Don't operate the transducer if the rope is buckled or damaged. A ripping of the rope may lead to injuries or damaging the transducer.

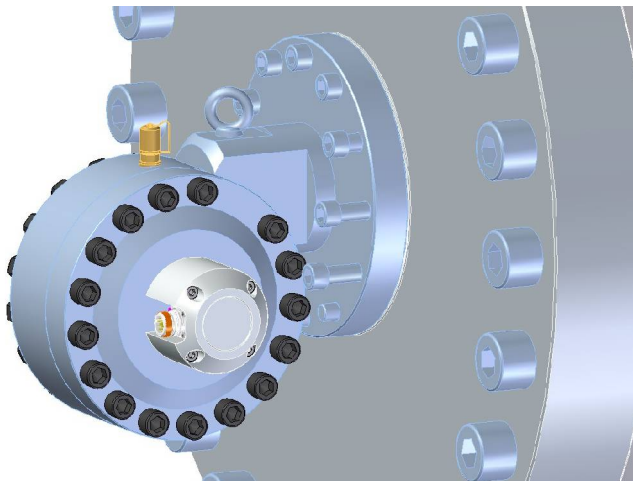

Screw tightly the bolts through the flange. Thighten crosswise to a first torque of about 100 Nm.

Note: bolts greased with MoS2 if not defined otherwise in the cylinder manual. Please refer to the cylinder manual.

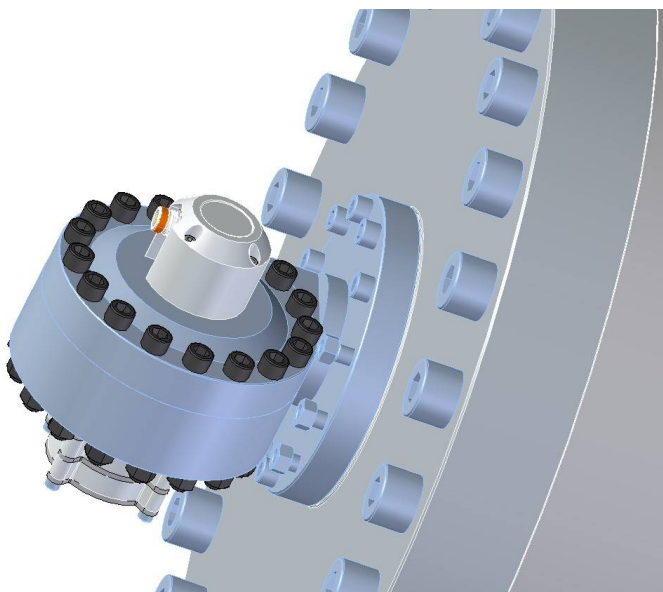

Screw tightly the nuts onto the stud bolts at the bottom side of the transducer. Thighten bolts and nuts crosswise to the specific torque. If not otherwise stated in the cylinder manual, apply torque as follows:

145 Nm for M16 quality 8.8
215 Nm for M16 quality 10.9
250 Nm for M16 quality 12.9

Note: nuts greased with MoS2 if not defined otherwise in the cylinder manual. Please refer to the cylinder manual.

PROVIDING SPARE PARTS

We keep some spare parts and repair kit at your disposal.

With regard to a quick delivery, please specify type and serial number of transducer as well as the required parts according to the list of spare parts.

However, since we are not able to have all components on stock at any time, we recommend to keep your own stock of repair kit to avoid any expensive standstills.

View - encoder and attachment parts

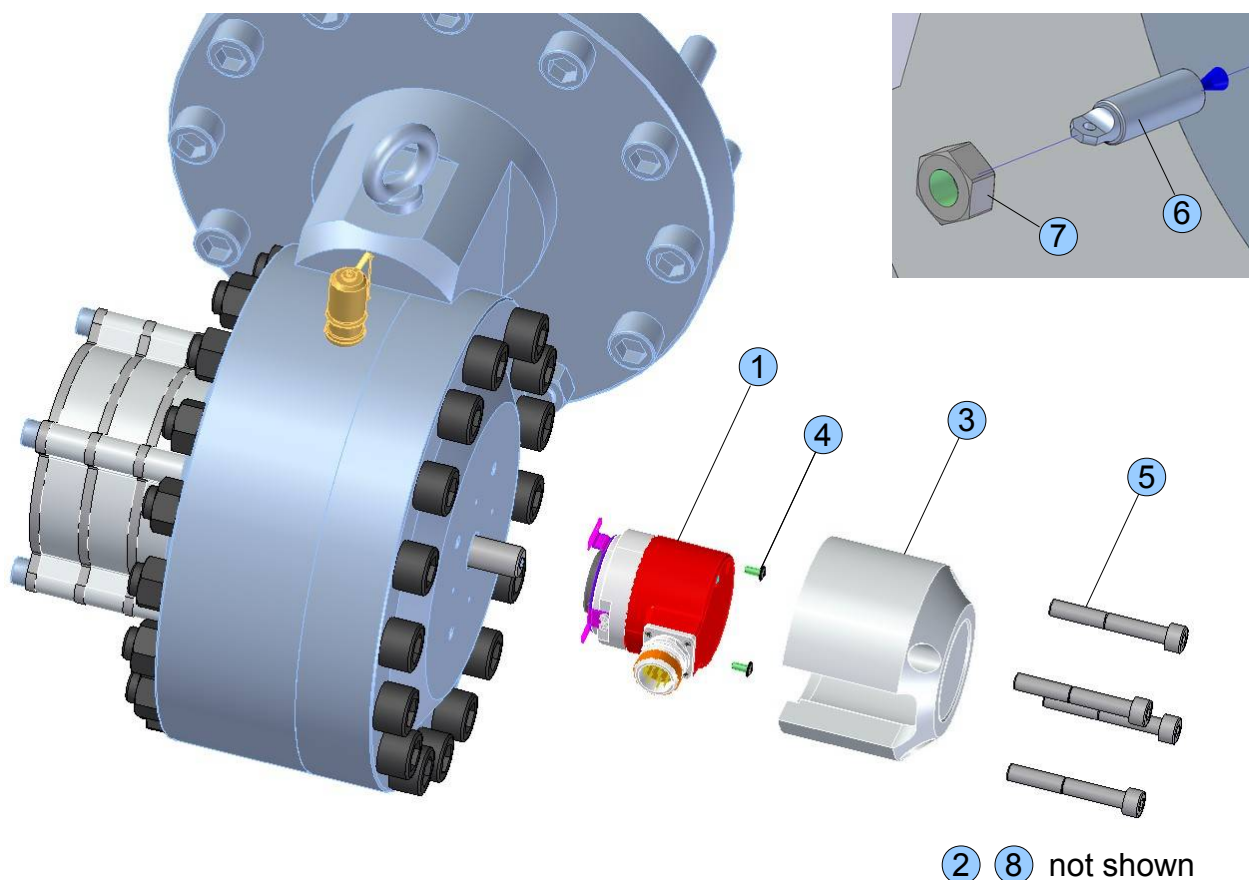

Part list - encoder and attachment parts

SX300-15-SSI-F1 (encoder and attachment parts)		
no.	description	quantity
1	encoder kuebler 8.5883.6624.G322	1
2	mating connector M23 straight CON012-S	1
3	encoder protection cap 99	1
4	encoder screw M3x8	2
5	encoder cap screw DIN 912 M8x60	4
6	wire fixation unit M14 A2	1
7	counter nut DIN 934 M14 A2	1
8	wire rope protection cap	1

View - transducer

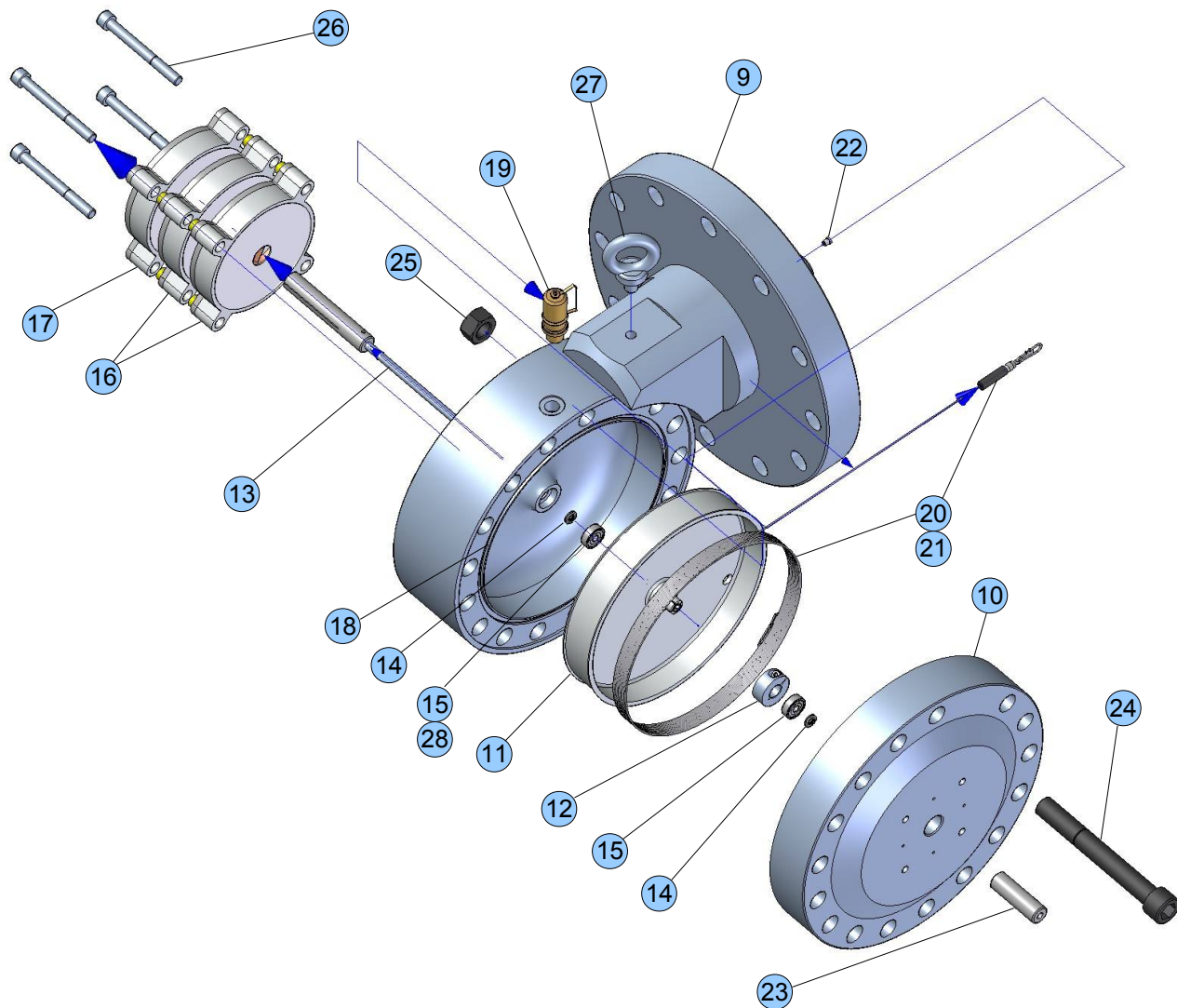

Part list - transducer

SX300-15-SSI-F1 (transducer parts)					
no.	description	qty	no.	description	qty
9	main housing	1	19	minimes 1620	1
10	main housing cap	1	20	wire set 15m	1
11	wire capstan	1	21	wire crimp	2
12	clamp ring	1	22	guide eyelet	1
13	rotation shaft	1	23	encoder adapter 15	1
14	pressure seal TRE	2	24	housing screw DIN912 M16x13 (12.9)	16
15	bearing 626ZZ	2	25	housing nut DIN934 M16 (12)	16
16	spring type 1	2	26	spring housing screw DIN912 M8x85 A2	4
17	spring type 2	1	27	eye bolt DIN580 M10 A2	1
18	o-ring 190,1x3,53 NBR90	1	28	washer	2

GENERAL INFORMATION

GENERAL INFORMATION

Address of transducer manufacturer

WayCon Positionsmesstechnik GmbH
Mehlbeerenstr. 4
82024 Taufkirchen
Germany

+4989679713-0 Tel
+4989679713-250 Fax
info@waycon.de
<http://www.waycon.de>

Address of local distributor

please refer to our distributor list

<http://www.waycon.biz>

Product identification

All transducers are marked with label and security notes. Additionally, the serial number is stamped into the transducer housing nearby the test point. For any questions regarding the transducer or spare parts orders, please specify the type and serial number.



We reserve the right to alter the specification without prior notice

WayCon Positionsmesstechnik GmbH

e-mail: info@waycon.de

internet: www.waycon.de

Head Office

Mehlbeerenstr. 4

82024 Taufkirchen

Tel. +49 (0)89 67 97 13-0

Fax +49 (0)89 67 97 13-250

Office Köln

Auf der Pehle 1

50321 Brühl

Tel. +49 (0)2232 56 79 44

Fax +49 (0)2232 56 79 45

WayCon

Positionsmesstechnik