

Digital Gauge

DG10B DG25B

**High accuracy, rugged gauges.
Suitable for installation on machines**

- Magnetic principle
- Excellent resistance to workshop conditions (BP/BS: IP64). Resistant to oil, water, dust, vibrations and shocks.
- Accuracy: $\pm 1 \mu\text{m}$
- Resolution: $0.5 \mu\text{m}$
- Measuring range: 10 mm / 0.39" and 25 mm / 0.98"
- High measuring force (BP/BS)
- Low measuring force (BN/BL)
- Easy installation
- A variety of accessories available (See "Accessories for Gauges")

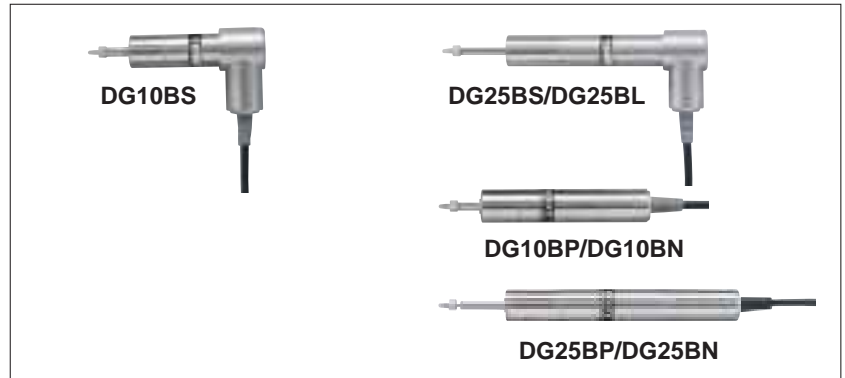

Specifications

Model	DG10BP	DG10BS	DG10BN	DG25BP	DG25BS	DG25BN	DG25BL
Measuring range	10 mm / 0.39"			25 mm / 0.98"			
Resolution	0.5 μm						
Accuracy (at 20 °C / 68 °F)	$\pm 1 \mu\text{m}$						
Measuring force	Upward	All directions: 4.9 N or less	0.3 \pm 0.25 N	All directions: 4.9 N or less	0.4 \pm 0.3 N		
	Lateral		0.6 \pm 0.3 N		0.7 \pm 0.35 N		
	Downward		0.8 \pm 0.35 N		1 \pm 0.4 N		
Protective design grade	Equivalent to IP64		—	Equivalent to IP64		—	
Sealing (oil, water, dust)	Oil sealing, O-rings, Y-gaskets		—	Oil sealing, O-rings, Y-gaskets		—	
Mounting stem diameter	$\varnothing 20_{-0.013}^0$ mm						
Operating temperature	0 °C to 50 °C / 32 °F to 122 °F						
Storage temperature	-20 °C to 60 °C / -4 °F to 140 °F						
Cable length	5 m/16.4'						
Feeler	Feeler tipped with 2.5 mm dia. carbide ball with M2.5 x 0.45 screw on fitting end (DZ122)						
Mass (excl. cable unit)	0.1 kg/0.22 lbs			0.2 kg/0.44 lbs			
Option	None		Air lifter DZ-161 mountable	None		Air lifter DZ-161 mountable	

Dimensions

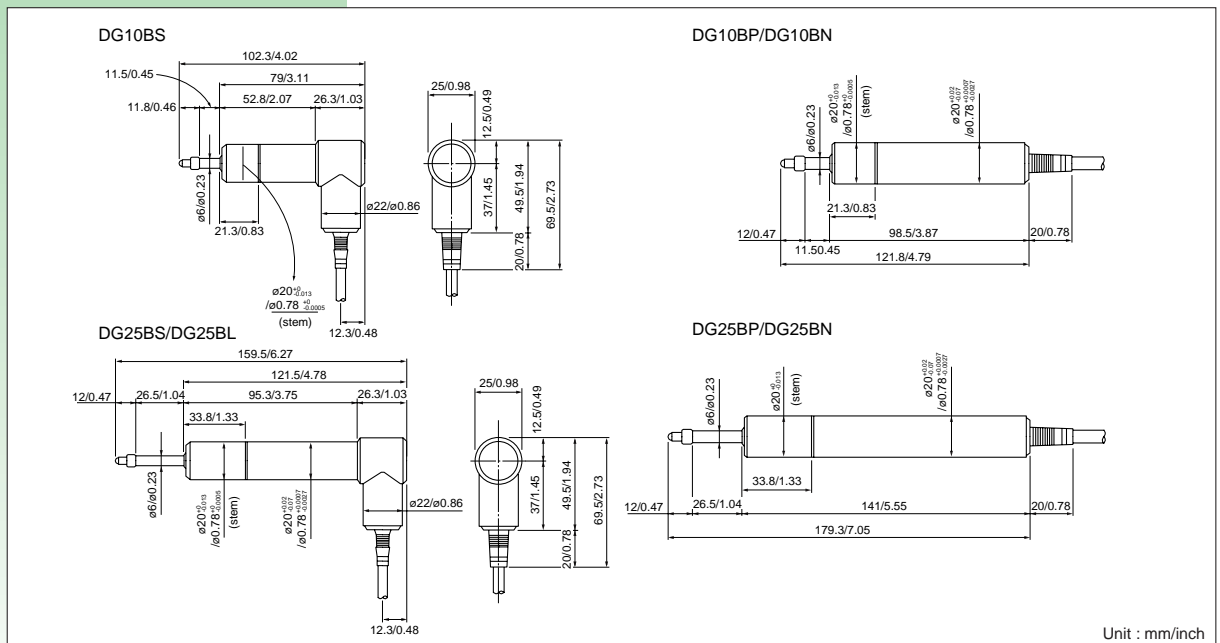

Digital Gauge

DG50B DG100B DG155B DG205B

Gauges

High accuracy, rugged gauges. Suitable for installation on machines

- Magnetic principle
- Excellent resistance to workshop conditions (BP: IP64). Resistant to oil, water, dust, vibrations and shocks.
- Accuracy: $\pm 1 \mu\text{m}$ (DG50BP/50BN), $\pm 2 \mu\text{m}$ (DG100BP/100BN), $\pm 2.5 \mu\text{m}$ (DG155BP), $\pm 3 \mu\text{m}$ (DG205BP)
- Resolution: 0.5 μm
- Measuring range: 50 mm / 1.96", 100 mm / 3.93", 155 mm / 6.10" and 205 mm / 8.07"
- High measuring force (DG50BP/100BP)
- Low measuring force (DG50BN/100BN)
- Magnet feeler (DG155BP/205BP)
- Easy installation
- A variety of accessories available (See "Accessories for Gauges")

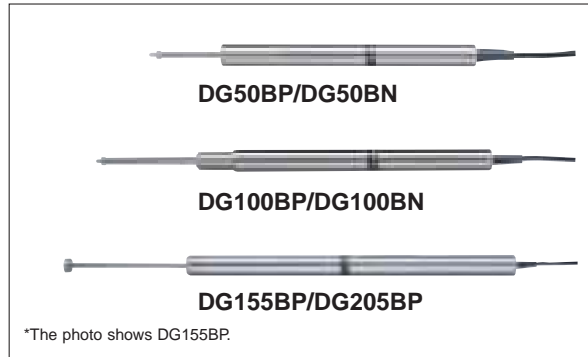

Specifications

Model	DG50BP	DG50BN	DG100BP	DG100BN	DG155BP	DG205BP
Measuring range	50 mm/ 1.96"		100 mm/ 3.93"		155 mm/ 6.10"	205 mm/ 8.07"
Resolution	0.5 μm					
Accuracy (at 20 °C /68 °F)	$\pm 1 \mu\text{m}$		$\pm 2 \mu\text{m}$		$\pm 2.5 \mu\text{m}$	$\pm 3 \mu\text{m}$
Measuring force	Upward	All directions: 6.2 N or less	—	All directions: 9.3 N or less	—	—
	Lateral		$0.9 \pm 0.4 \text{ N}$		$1.8 \pm 0.65 \text{ N}$	
	Downward		$1.3 \pm 0.5 \text{ N}$		$2.7 \pm 0.55 \text{ N}$	
Protective design grade	Equivalent to IP64		Equivalent to IP64		Equivalent to IP64	
Sealing (oil, water, dust)	Oil sealing,O-rings,Y-gaskets		Oil sealing,O-rings,Y-gaskets		Oil sealing, O-rings, Y-gaskets	
Mounting stem diameter	$\varnothing 20_{-0.013}^0 \text{ mm}$				$\varnothing 32_{-0.05}^0 \text{ mm}$	
Operating temperature	0 °C to 50 °C /32 °F to 122 °F					
Storage temperature	-20 °C to 60 °C / -4 °F to 140 °F					
Cable length	5m/16.4'					
Feeler	carbide ball tipped feeler (DZ122)		carbide ball tipped feeler (DZ121)		DZ181 carbide ball tipped feeler	
Magnetic feeler	—		—		Attraction force: 10N Lateral slippage force:2.7N	
Mass (excl. cable unit)	0.35 kg/ 0.77 lbs		0.6 kg/ 1.32 lbs		1.1 kg/ 2.43 lbs	1.3 kg/ 2.87 lbs
Option	None	Air lifter DZ-161 mountable	None	Air lifter DZ-161 mountable	None	

Dimensions

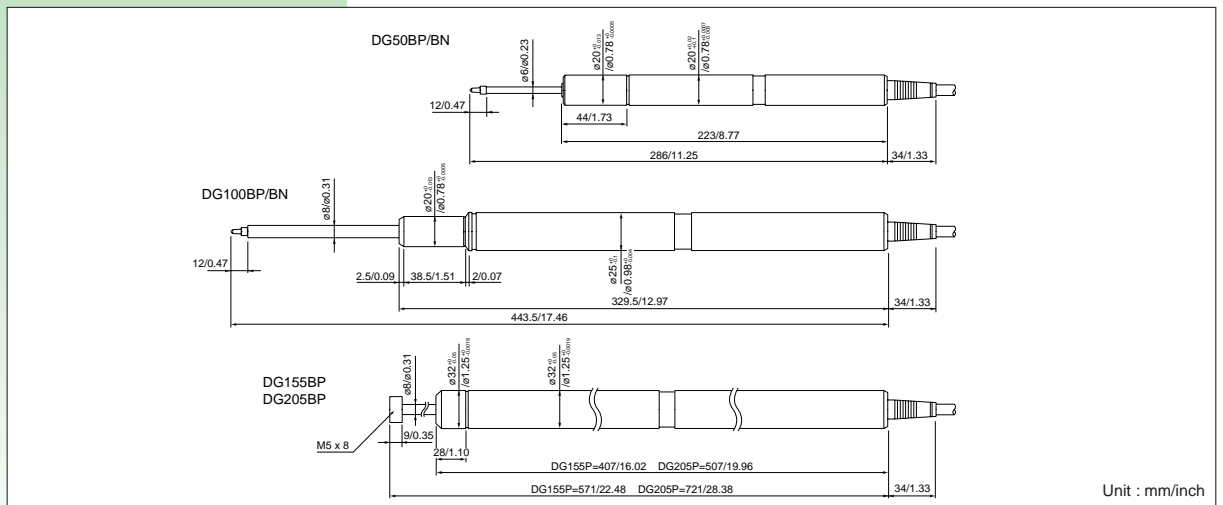

- A/B quadrature signal output with differential line driver
- Highly reliable Magnescale® principle
- Two types of power supply voltage + 5V DC and + 12 to + 24V DC
- Compact design (outside diameter \varnothing 8 mm: DG805/ 810) and a line up to cover a wide measuring range (5 mm to 205 mm)

Specifications (Gauges)

Model	DG805 BLM/BLE FLM/FILE	DG810 BM/BE FM/FE	DG810 BLM/BLE FLM/FILE	DG10 BPM/BPE	DG10 BSM/BSE	DG10 BNM/BNE	DG25 BPM/BPE	DG25 BSM/BSE	DG25 BNM/BNE	DG25 BLM/BLE
Measuring length L mm (inch)	5.2mm			10 mm			25 mm			
Resolution	0.5/ (1)/ (2)/ (5)/ (10) μ m (Switch-selectable)									
Accuracy (at 20 °C /68 °F)	$\pm 1 \mu$ m									
Measuring force (at 20 °C /68 °F)	Upward	0.35 \pm 0.25N	0.4 \pm 0.3N	All directions 4.9N or less		0.3 \pm 0.25N	All directions 4.9N or less		0.4 \pm 0.3N	
	Lateral	0.40 \pm 0.25N	0.5 \pm 0.3N			0.6 \pm 0.3N			0.7 \pm 0.35N	
	Downward	0.45 \pm 0.25N	0.6 \pm 0.3N			0.8 \pm 0.35N			1 \pm 0.4N	
Protection grade	—			IP64 equivalent		—		IP64 equivalent		—
Mounting stem diameter	\varnothing 8 (0/ -0.009 mm)/ \varnothing 0.31" (+0/ -0.0004") L type: \varnothing 9.5(+0/-0.009 mm)/ \varnothing 0.37" (+0/ -0.0004")			\varnothing 20(0/ -0.013 mm)/ \varnothing 0.79" (+0/ -0.0005")						
Lift lever	N/A			N/A		DZ161(Option)		N/A		DZ161(Option)
Air lifter	DZ801(Option) Note 1	N/A		DZ801(Option) Note 1		DZ174-010 (Option) Note 1		DZ174-025 (Option) Note 1		
Cable length	5 m/ 16.4"									
Operating temperature	0 to 50 °C / 32 °F to 122 °F									
Storage temperature	-20 to 60 °C / 4 °F to 140 °F									
Feeler	Feeler \varnothing 3mm carbide ball with M2.5 x 0.45 screw on fitting end (DZ123)			Feeler \varnothing 2.5 mm carbide ball with M2.5 x 0.45 screw on fitting end (DZ122)						
Mass (excl. cable unit)	20 g		40 g		100 g			200 g		

Specifications (Gauges)

Model	DG50 BPM/BPE	DG50 BNM/BNE	DG100 BPM/BPE	DG100 BNM/BNE	DG110 BM/BE	DG155 BPM/BPE	DG205 BPM/BPE
Measuring length L mm (inch)	50 mm		100 mm		110 mm	155 mm	205 mm
Resolution	0.5/ (1)/ (2)/ (5)/ (10) μ m (Switch-selectable)						
Accuracy (at 20 °C /68 °F)	$\pm 1 \mu$ m			$\pm 2 \mu$ m		$\pm 2.5 \mu$ m	$\pm 3 \mu$ m
Measuring force (at 20 °C /68 °F)	Upward	—		All directions 9.3N or less	—	Resistance against slip: 2.7N (Do not have an internal spring)	
	Lateral	6.2N or less			1.8 \pm 0.65N	—	
	Downward	0.9 \pm 0.4N 1.3 \pm 0.5N			2.7 \pm 0.55N	1.55 \pm 0.15N (Note2)	
Protection grade	IP64 equivalent		—		IP64 equivalent		—
Mounting stem diameter	\varnothing 20 (+0/-0.013 mm) / \varnothing 0.79" (+0/ -0.0005")				\varnothing 20 (+0/-0.03 mm) \varnothing 0.79" (+0/-0.001")	\varnothing 32 (+0/ -0.05 mm) \varnothing 1.26" (+0/ -0.002")	
Lift lever	N/A		DZ161 (Option)		DZ161 (Option)		DZ161 (Option)
Air lifter	DZ174-050 (Option) Note 1		N/A		DZ161 (Included)		
Cable length	5m/ 16.4'				2 m/ 6.56'		5 m/ 16.4'
Operating temperature	0 to 50 °C / 32 °F to 122 °F						
Storage temperature	-20 to 60 °C / -4 °F to 140 °F						
Feeler	Feeler tipped with \varnothing 2.5 mm carbide ball with M2.5 x 0.45 screw on fitting end (DZ122)		Feeler tipped with \varnothing 2.5 mm carbide ball with M2.5 x 0.45 screw on fitting end (DZ121)				—
Magnetic feeler	N/A		N/A				DZ181 (Included) Attraction force : 10N
Mass (excl. cable unit)	350 g		600 g		1150 g	1100 g	1300 g

Note1: Tubing for compressed air device can be attached

Note2: The measurement force values given apply when DZ-581 measuring force balancer is not used. By using a measuring force balancer (option), it is possible to reduce the measuring force to a minimum of 0.3N. The measuring force will be constant regardless of spindle position.

Specifications (Interpolator)

Model	DG-M	DG-E
Power supply voltage	DC 5 V \pm 5 % (Correspond to remote sensing function)	DC 11 V to 28 V (Correspond to remote sensing function)
Power consumption	300 mA (Maximum)	150 mA (Maximum)
Output interface	Based on EIA-422 (Line driver:AM 26C31 or equivalent)	
Output signal	A/B quadrature signal	
Resolution	0.5,1,2,5,10 μ m (0.00025",0.0005",0.001",0.0025",0.005") selectable	
Maximum response speed	1 m/s	
Minimum phase difference	200 ns	
Alarm	The output phase difference varies with the measuring speed.	
	A/B quadrature output of this probe turns to high impedance for 10 to 20 ms when excessive speed or cable disconnection alarm occurs.	
	If the cause is removed, the alarm signal is automatically reset.	
Output connector	MDR10214-52A2JL (3M)	
Dimensions	125 x 28 x 28 (mm) (not including projecting parts)	
Operating temperature	0 to 40/ 32 °F to 104 °F	
Storage temperature	-20 to 60/ -4 °F to 140 °F	
Mass (excl. cable and gauge part)	150 g	

Digital Gauge

DG-M/E Series

Dimensions

